

Standard Spacer Couplings

Full-flex spacer couplings are used for 4 bearing installations with extended shaft separations. Tabulated below are spacers for industry standard shaft separations, C_L .

Type EB exposed bolt spacers and Type SB shrouded bolt spacers for standard shaft separations are normally in stock. Other lengths are manufactured to order.

Spacer length, L , is calculated by subtracting the standard full-flex, close coupled gap, C , from the shaft separation, C_L .

$$L = C_L - C \text{ (full-flex, close coupled)}$$

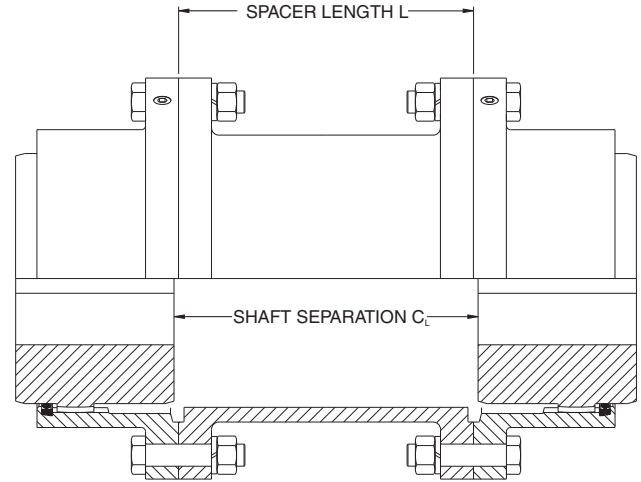

Spacer Part Numbers

Stock Spacer Part Numbers
Type SB (Shrouded Bolts)

Coupling Size	Shaft Separation							
	3 1/2"		4 3/8"		5"		7"	
	Part No.	Wt.	Part No.	Wt.	Part No.	Wt.	Part No.	Wt.
1 1/2	1 1/2 SB SPR350	6	1 1/2 SB SPR438	7	1 1/2 SB SPR500	8		
2	2 SB SPR350	8	2 SB SPR438	9	2 SB SPR500	10	2 SB SPR700	12
2 1/2					2 1/2 SB SPR500	14	2 1/2 SB SPR700	17
3					3 SB SPR500	17	3 SB SPR700	20
3 1/2					3 1/2 SB SPR500	27		

Note: Spacer part number references the shaft separation, not the actual length of the spacer.

Stock Spacer Part Numbers
Type EB (Exposed Bolts)

Coupling Size	Shaft Separation			
	5"		7"	
	Part No.	Wt.	Part No.	Wt.
1 1/2	1 1/2 EB SPR500	8		
2	2 EB SPR500	10	2 EB SPR700	12
2 1/2	2 1/2 EB SPR500	14		
3	3 EB SPR500	17		

LEF Spacer Couplings

Limited End Float (LEF) spacer couplings are used for sleeve bearing motor applications with extended shaft separations. LEF spacers are supplied with steel LEF plates and pilot rings.

Spacer length, L_{LEF} , is calculated by subtracting the LEF full-flex, close coupled gap, C_{LEF} , from the shaft separation, C_L .

$$L_{LEF} = C_L - C_{LEF} \text{ (full-flex, close coupled)}$$

LEF spacers are shorter than standard spacers for a given shaft separation, and are manufactured to order.

Note: Spacer part number references the shaft separation, not the actual length of the spacer.

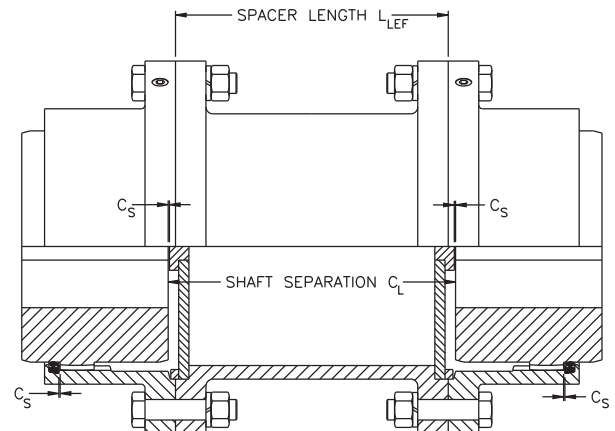

Coupling Greases

KOP-FLEX offers greases specifically designed for use in coupling applications. For proper lubrication and long service life, use KSG Standard Coupling Grease, or KHP High Performance Coupling Grease. See pages 170-172 for detailed specifications.